

Anchor channel type JTA W 54/43

JTA W 54/43

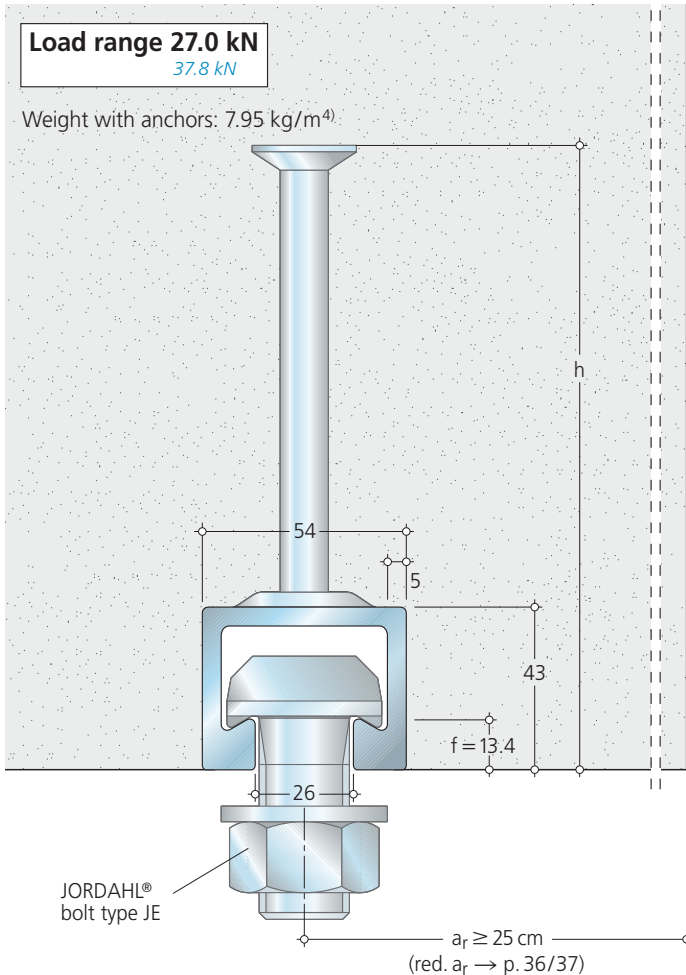

**Load range 27.0 kN**  
37.8 kN

Weight with anchors: 7.95 kg/m<sup>4</sup>

Design resistance to Eurocode

$$F_{Rd} = perm. F \times 1.4$$

The design values of the load bearing capacities are shown in *italics* in the tables.

Locking plates JGM B, M10-16



gv, A4  
→ p. 56

Notched toothed bolt



Grade 8.8,  $f_v$  → p. 41, 54

- JKB M 16 × 60  
perm. F = 5.0 kN with  $M_A = 200$  Nm
- JKB M 20 × 60  
perm. F = 7.5 kN with  $M_A = 400$  Nm

Type	<b>JTA W 54/43</b>	
Material Design	S275JR $f_v$ , wb	
permissible point load [kN] <sup>1)</sup> ≥ C 20/25	27.0 (32.0) 37.8 (44.8)	
Anchor design <sup>2)</sup>	R	I 125
Installation height h [mm]	195	170
Filler	Polystyrene filling (PS)	

Lengths supplied: JTA W 54/43

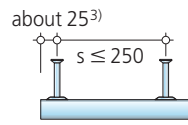

	Length [mm]	Anchor (no.)	Anchor spacing s
Short pieces	150 <sup>3)</sup>	2	100
	200	2	≤ 150
	250	2	≤ 200
	300	2	≤ 250
	350 – 550	3	≤ 250
	600 – 800	4	≤ 250
	850 – 1050	5	≤ 250
Cut lengths	1050 < L < 6000 on request		≤ 250
Stock lengths	6000 (-0/+50)	25	≤ 250

- 1) Max. permissible load as per Building Approval. C 20/25  $\Delta$  B 25.  
Bracketed values apply to C 30/37  $\Delta$  B 35.  
Permissible loads for the respective application → p. 33.
- 2) Anchor design: R = round anchor (standard design); I = weld-on anchor.  
Supply not binding.
- 3) In the case of round anchors, end spacing is about 35 mm, anchor spacing 80 mm.
- 4) Weight per metre for mill finish steel  
(for galvanized profiles: weight per metre × 1,10)  
(for stainless steel: weight per metre × 1,02)

**Ordering example  
Anchor channels**

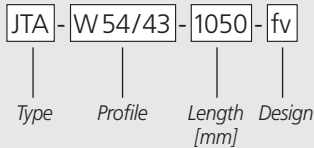

**Ordering example  
JORDAHL® bolts type JE**

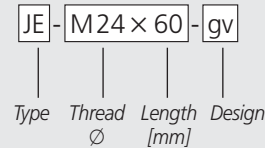

Installation of anchor channels JTA W 54/43 in factory floors, for example for fixing finished parts in concrete work. Optimization of the fabrication process as a result of rapid changeover.



**JORDAHL® bolts type JE M24 and type JB**

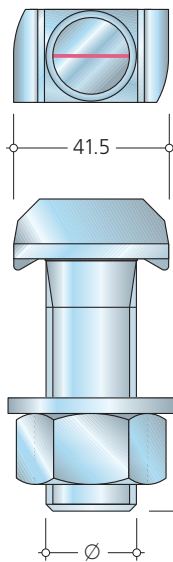

**Associated bolt type JE**

If there is less utilization of the load range of the profile, the smaller type JB bolts can also be used.

Bolt length l

gv 4.6 = electrogalvanized in strength class 4.6  
fv 4.6 = hot-dip galvanized in strength class 4.6  
fv 8.8 = hot-dip galvanized in strength class 8.8  
A4-50 = stainless steel 1.4401/1.4404/1.4571 in strength class 50  
FA-70 = stainless steel 1.4462 in strength class 70

**Bolt range JB** (picture → p. 15)

Length l [mm]	Bolt range JB				Bolt JE
	JB M 10	JB M 12	JB M 16	JB M 20	JE M 24
30	gv 4.6	gv 4.6 A4-50	gv 4.6 A4-50		
35				gv 4.6	
40	gv 4.6	gv 4.6 A4-50	gv 4.6 A4-50		
45				gv 4.6 A4-50	
50	gv 4.6	gv 4.6 A4-50	gv 4.6, fv 4.6 A4-50		
55				gv 4.6 A4-50	
60		gv 4.6	gv 4.6, fv 4.6, fv 8.8 A4-50		gv 4.6 on request
65				gv 4.6, fv 8.8	
75				gv 4.6 A4-50	
80	gv 4.6	gv 4.6	gv 4.6, fv 4.6 A4-50		
100		gv 4.6 A4-50	gv 4.6	gv 4.6, fv 8.8 A4-50 FA-70	
125		gv 4.6	gv 4.6	gv 4.6 A4-50	
150		gv 4.6	gv 4.6 A4-50	gv 4.6 A4-50 FA-70	
200				gv 4.6	
300		gv 4.6	gv 4.6	gv 4.6	

**Permissible bolt loads**

under tension, oblique tension or shear load

Type Ø	Recommended tightening torque M <sub>A</sub> [Nm] <sup>4)</sup>	Permissible load perm. F <sup>1)</sup> / F <sub>Rd</sub> [kN]		Permissible bending moment perm. M <sup>2)3)</sup> / M <sub>Rd</sub> [Nm]	
		4.6	A4-50	4.6	A4-50
JB M 10	15	6.4 9.0	6.4 9.0	10.0 14.0	8.7 12.2
JB M 12	25	9.3 13.0	9.3 13.0	17.5 24.5	15.3 21.4
JB M 16	60	17.3 24.2	17.3 24.2	44.4 62.2	38.8 54.3
JB M 20	120	27.0 37.8	27.0 37.8	86.5 121.1	75.7 106.0
JE M 24	200	38.8 54.3	—	149.7 209.6	—

Notes → p. 40

**Associated edge spacings [cm]**

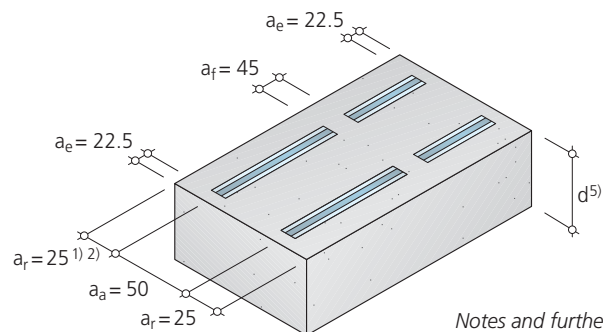

Notes and further minimum spacings → p. 35